

**FEATURES:**

- ✧ 400 Watts peak pulse power per line ( $t_P=8/20\mu s$ )
- ✧ Protects one bi-directional I/O line
- ✧ Low clamping voltage
- ✧ Working voltage:24V
- ✧ Low leakage current
- ✧ RoHS compliant

**MAIN APPLICATIONS**

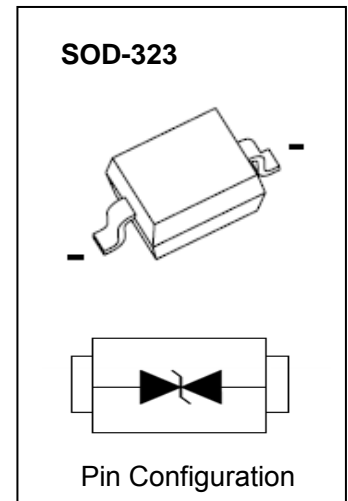
- ✧ Cell phone handsets and accessories
- ✧ Microprocessor based equipment
- ✧ Personal digital assistants (PDA's)
- ✧ Notebooks, desktops, and servers
- ✧ Portable instrumentation

**PROTECTION SOLUTION TO MEET**

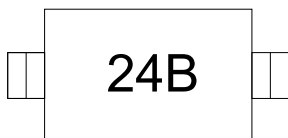
- ✧ IEC61000-4-2 (ESD)  $\pm 30kV$  (air),  $\pm 30kV$  (contact)
- ✧ IEC61000-4-4 (EFT) 40A (5/50ns)
- ✧ IEC61000-4-5 (Lightning) 8A(8/20 $\mu s$ )

**MECHANICAL CHARACTERISTICS**

- ✧ SOD-323 package
- ✧ Molding compound flammability rating : UL 94V-0
- ✧ Weight 5 milligrams (approximate)
- ✧ Quantity per reel : 3,000pcs
- ✧ Lead finish : lead free



**MARKING CODE**



**ORDERING INFORMATION**

PART No.	PACKAGE TYPE	QUANTITY(PCS) REEL	DESCRIPTION
TESDB24D3	SOD-323	3,000	7 inch reel pack

**ABSOLUTE MAXIMUM RATINGS** ( $T_A=25^{\circ}\text{C}$ , RH=45%-75%, unless otherwise noted)

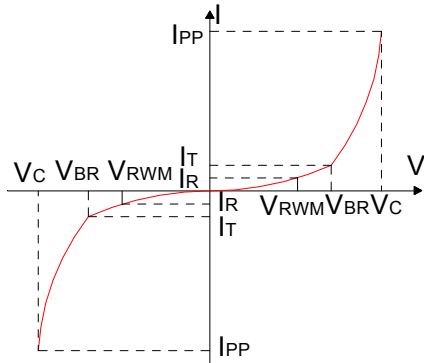
Parameter	Symbol	Value	Unit
Peak pulse power dissipation on 8/20 $\mu\text{s}$ waveform	$P_{PP}$	400	W
ESD per IEC 61000-4-2 (Air) ESD per IEC 61000-4-2 (Contact)	$V_{ESD}$	+/- 30 +/- 30	kV
Lead soldering temperature	$T_L$	260 (10 sec.)	$^{\circ}\text{C}$
Operating junction temperature range	$T_J$	-55 to +125	$^{\circ}\text{C}$
Storage temperature range	$T_{STG}$	-55 to +150	$^{\circ}\text{C}$

**ELECTRICAL CHARACTERISTICS** ( $T_A=25^{\circ}\text{C}$ )

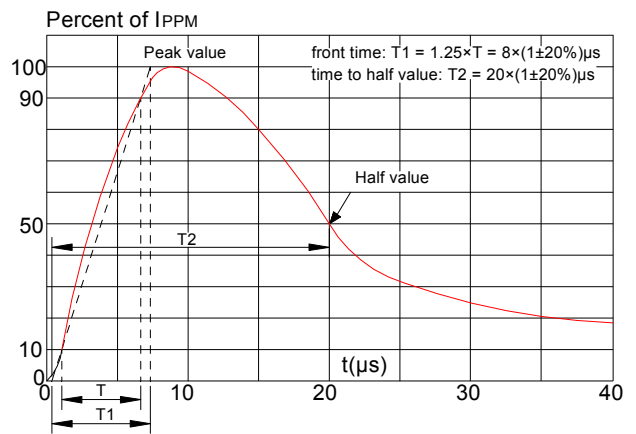
Parameter	Symbol	Conditions	Min	Typ	Max	Unit
Reverse working voltage	$V_{RWM}$				24	V
Reverse breakdown voltage	$V_{BR}$	$I_T=1\text{mA}$	26.7			V
Reverse leakage current	$I_R$	$V_{RWM}=24\text{V}$			1	$\mu\text{A}$
Clamping voltage (I/O pin to Ground)	$V_C$	$I_{PP}=1\text{A}, t_P=8/20\mu\text{s}$			40	V
		$I_{PP}=8\text{A}, t_P=8/20\mu\text{s}$			50	V
Junction capacitance	$C_J$	$V_{RWM}=0\text{V}, f=1\text{MHz}$		30	35	pF

### RATINGS AND V-I CHARACTERISTICS CURVES ( $T_A=25^{\circ}\text{C}$ , unless otherwise noted)

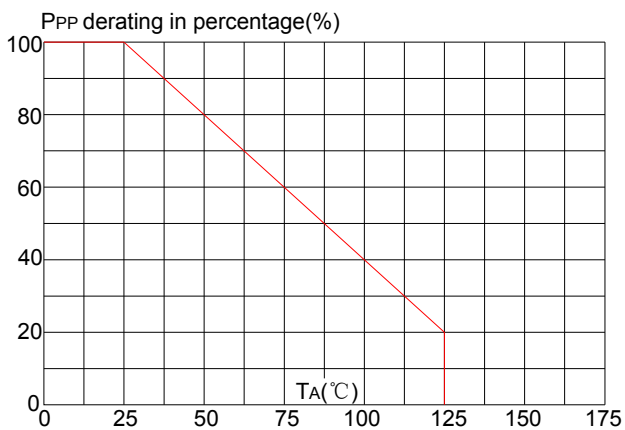
**FIG.1: V- I curve characteristics (Bi-directional)**



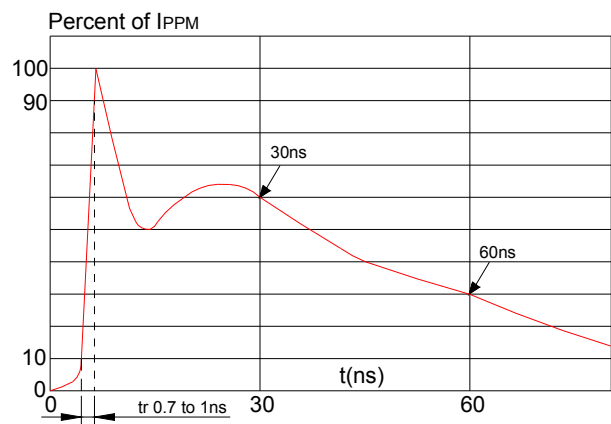
**FIG.2: Pulse waveform (8/20 $\mu\text{s}$ )**



**FIG.3: Pulse derating curve**

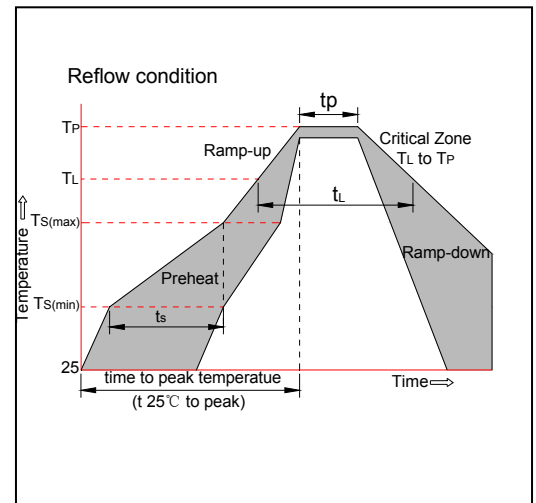


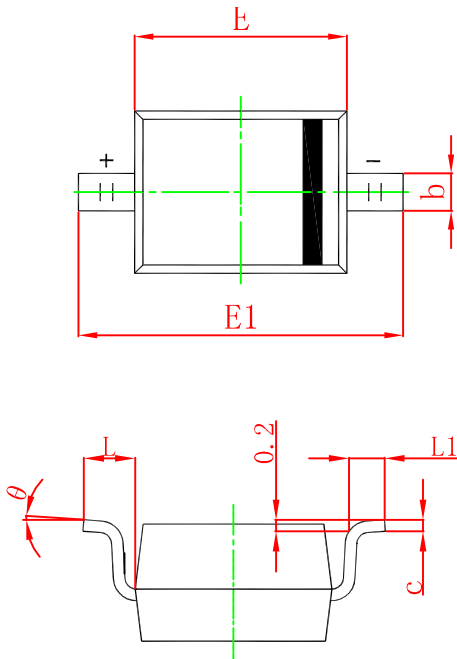
**FIG.4: ESD clamping (30kV contact)**



## SOLDERING PARAMETERS

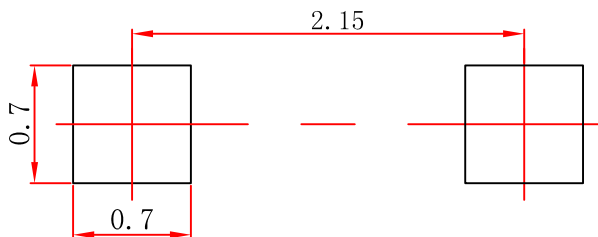
Reflow Condition		Pb-Free assembly (see figure at right)
Pre Heat	-Temperature Min ( $T_{s(min)}$ )	+150°C
	-Temperature Max( $T_{s(max)}$ )	+200°C
	-Time (Min to Max) ( $t_s$ )	60-180 secs.
Average ramp up rate (Liquidus Temp ( $T_L$ ) to peak)		3°C/sec. Max
$T_{s(max)}$ to $T_L$ - Ramp-up Rate		3°C/sec. Max
Reflow	-Temperature( $T_L$ )(Liquidus)	+217°C
	-Temperature( $t_L$ )	60-150 secs.
Peak Temp ( $T_P$ )		+260(+0/-5)°C
Time within 5°C of actual Peak Temp ( $t_p$ )		20-40secs.
Ramp-down Rate		6°C/sec. Max
Time 25°C to Peak Temp ( $T_P$ )		8 min. Max
Do not exceed		+260°C





Symbol	Dimensions In Millimeters		Dimensions In Inches	
	Min.	Max.	Min.	Max.
A		1.000		0.039
A1	0.000	0.100	0.000	0.004
A2	0.800	0.900	0.031	0.035
b	0.250	0.350	0.010	0.014
c	0.080	0.150	0.003	0.006
D	1.200	1.400	0.047	0.055
E	1.600	1.800	0.063	0.071
E1	2.550	2.750	0.100	0.108
L	0.475 REF.		0.019 REF.	
L1	0.250	0.400	0.010	0.016
θ	0° - 8°		0° - 8°	

### SOD-323 Suggested Pad Layout



**Note:**

1. Controlling dimension: in millimeters.
2. General tolerance:  $\pm 0.05$  mm.
3. The pad layout is for reference purposes only.